

## Understanding and Eliminating RF Interference

Jim Brown K9YC  
Audio Systems Group, Inc.  
<http://audiosystemsgroup.com>

## Basic Interference Mechanisms

- Audio cables are antennas
  - Pin 1 problems
  - Shield-current-induced noise (SCIN)
  - Inadequate filtering of equipment ins and outs
  - Audiofool “DC-to-daylight” design philosophy
- Shield current can excite all of these

## Sources of Shield Current

- Noise voltage on “ground” at ends of cable
  - Filter capacitors on the power line
  - Leakage capacitance in power transformers
  - Current flowing in ground unrelated to audio system (motors, lighting equipment, etc.)
  - Wiring errors
- Induced by magnetic fields
  - Double-bonded neutrals
  - Big transformers and motors
- Radio transmitters (antenna action)

## The Pin 1 Problem

- Current flows on cable shields
  - Hum, buzz, RF
- If shield goes to shielding enclosure, current stays outside the box
- If shield goes to the circuit board, current goes inside the box!

## The Pin 1 Problem

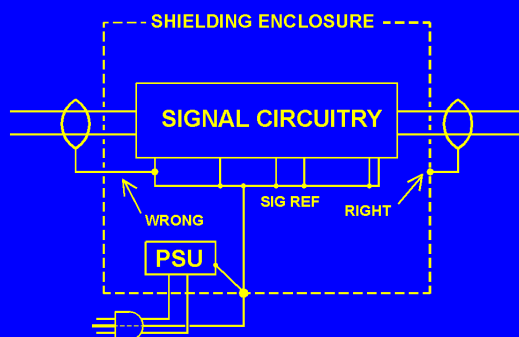

## The Pin 1 Problem

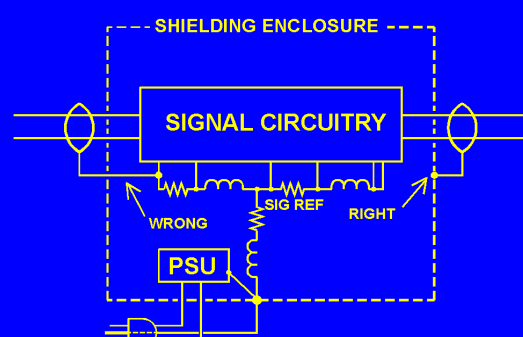

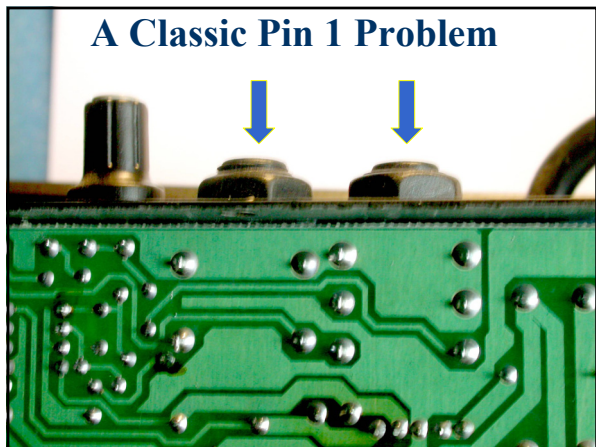
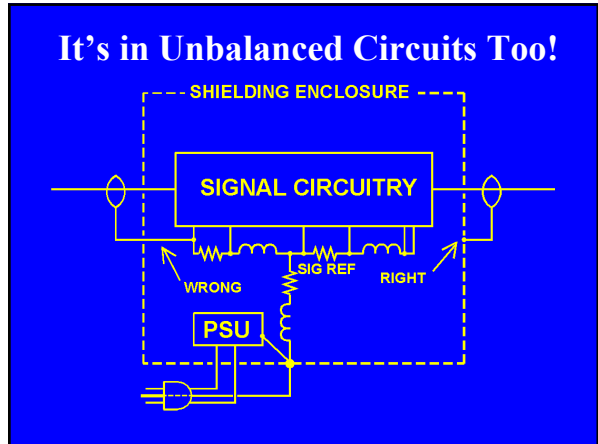
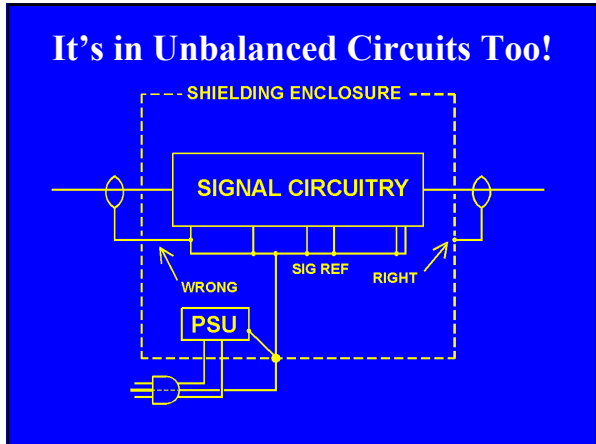

## RF in the Shack is a Pin 1 Problem

- Nearly all ham gear has pin 1 problems
  - Mic inputs
  - Keying inputs
  - Control inputs and outputs
- Nearly all computers have pin 1 problems
  - Sound cards
  - Serial ports

## Great Radio, Has Pin 1 Problems

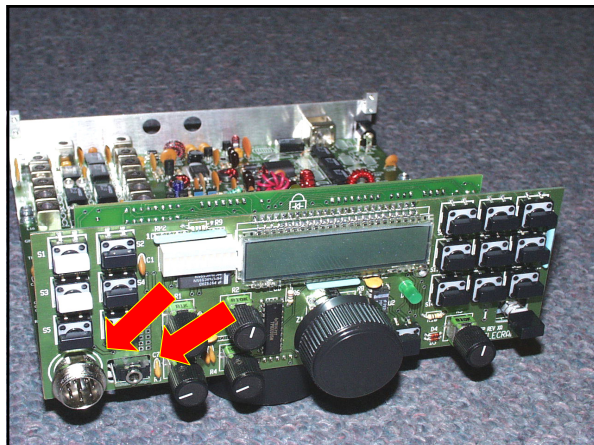

## A Pin 1 Problem? Maybe



## Where are the Chassis Connections for this laptop's sound card?

- Hint: It isn't an audio connector shell!
  - That metal is a shield, but not connected to connectors!
  - And the cover is plastic too!

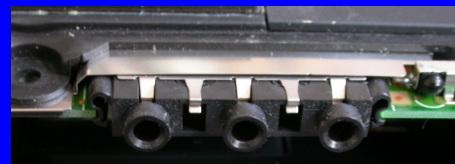

## Where are the Chassis Connections for this laptop's sound card?

Yes, it's the DB9 and DB25 shells!



## Too Much Bandwidth

- Wiring often puts RF on equipment inputs (and outputs)
- Equipment must be able to reject it!
- Audio spectrum ends at 20 kHz
  - Filters produce phase shift
  - Phase shift in multiple stages adds up
  - Small rolloffs (0.5 dB) add up
  - So 100 kHz is a reasonable cutoff
  - Going beyond 200 kHz is CRAZY!

## The AudioFool Viewpoint

- *The Myth:* “We can hear stuff above 20 kHz”
- *Reality:* Some distortion mechanisms DO produce audible artifacts from ultrasonic signals, but we hear the problems, not the signals!
- Intermodulation distortion (40 kHz – 30 kHz = 10 kHz)
- Slew rate limiting within electronics of ultrasonic output of a mic (or of square waves from a test generator)

## Golden Rules to Avoid RFI

- All wiring can act as an antenna
  - It can receive current if RF is present
  - It can transmit RF if RF current flows on it
- Radio signals cause current to flow
- Don't let that current cause problems

## Golden Rules to Avoid RFI

- Fix pin 1 problems
- Fix equipment with excessive bandwidth
  - Add low-pass filters at inputs
  - Input transformers are inherently good low-pass filters (Jensen, Lundahl)
  - Faraday shield blocks common mode

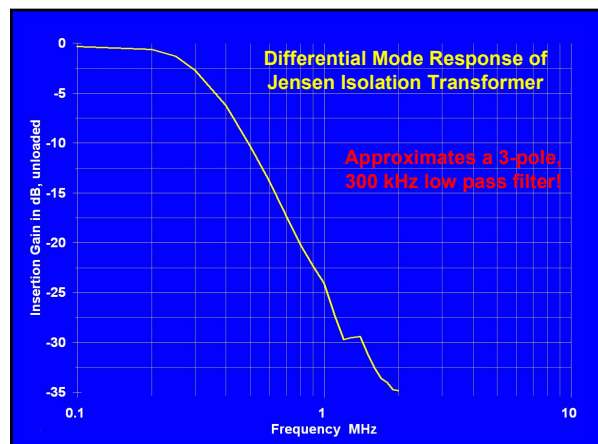

## Golden Rules to Avoid RFI

- Loudspeaker Cables
  - Always use TWISTED PAIR
  - Shielding is not important
  - Exotic cable is a waste of money
- Mic and Line level Cables
  - Avoid drain wires in shields
  - Use braid shielded cable
  - Use twisted pair (tighter twist helps too)

## Golden Rules to Avoid RFI

- Maximize audio levels on cables
  - Run output stages near their maximum levels
  - Set input gains near their minimum levels

## Critical Product Specifications

- Maximize input level
  - How much signal does it take to clip the input stage?
- Maximum output level
  - How much can the box put out cleanly?

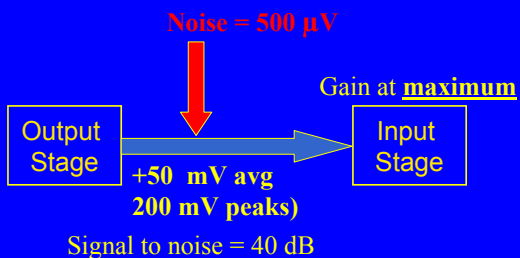
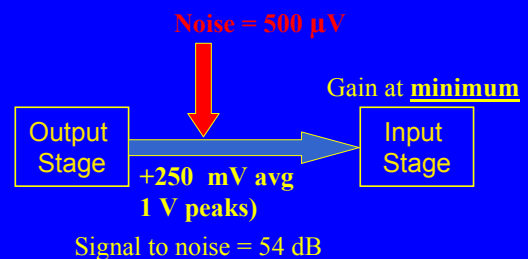

## Matching a Computer Output to a Transmitter Input

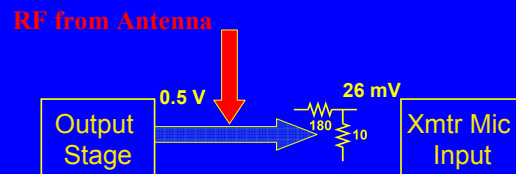

The pad attenuates the computer output to match the mic input. It also attenuates any hum, buzz, or RF picked up on the input wiring.

## Golden Rules to Avoid RFI

- RFI often enters equipment (and systems) by more than one path.
- Always assume that there are other paths!
- Take a methodical approach. Don't give up when one "right" technique doesn't fix it – keep on doing other "right" things. The "right" techniques really are right!

## Golden Rules to Avoid RFI

- And when that isn't enough:

## Ferrites can block the current!



## An AM Broadcast Choke



14 turns of mic cable around this ferrite can kill AM broadcast RFI

This "Clamp-On" forms a choke that can kill interference from FM and TV



## What's a Ferrite?

- A ceramic consisting of an iron oxide
  - manganese-zinc – MF, HF (AM broadcast, hams)
  - nickel-zinc – VHF, UHF (FM, TV, cell phones)
- Has permeability much greater than air
  - Better path for magnetic flux than air
  - Multiplies inductance of a wire passed through it
- Is increasingly lossy at higher frequencies
- Does not affect audio

## Permeability

- Symbol is  $\mu$ 
  - $\mu_0$  is permeability of free space (air, aluminum)
  - $\mu_r$  on data sheets is usually the relative permeability, referenced to free space
  - Subscript r usually omitted  $\mu$
- Typical  $\mu$  values
  - Steel 1,000
  - Stainless steel 500
  - Mu-metal 20,000
  - Ferrites 100 – 3,000

## A (too) simple equivalent circuit of a wire passing through a ferrite



## $R_s$ and $X_s$ vary with frequency!

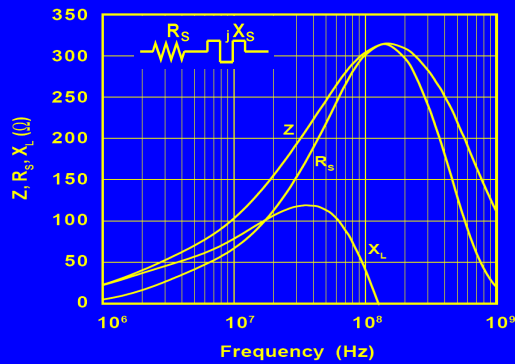

## A Ferrite Optimized for UHF

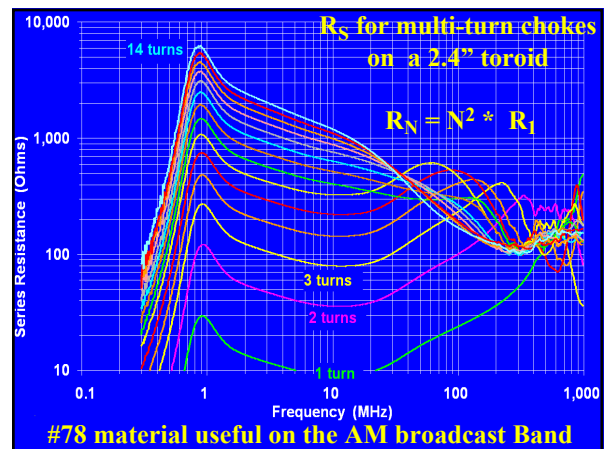
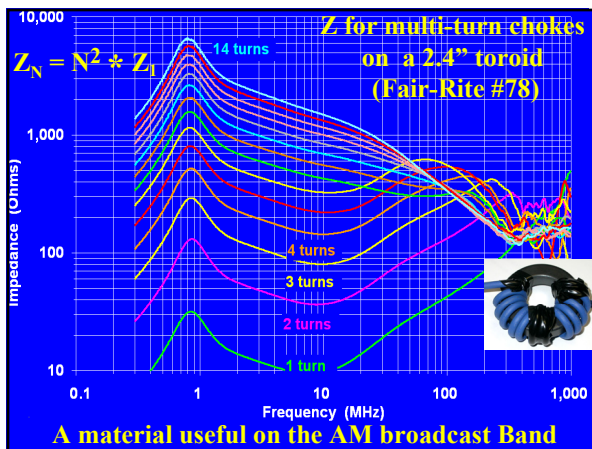
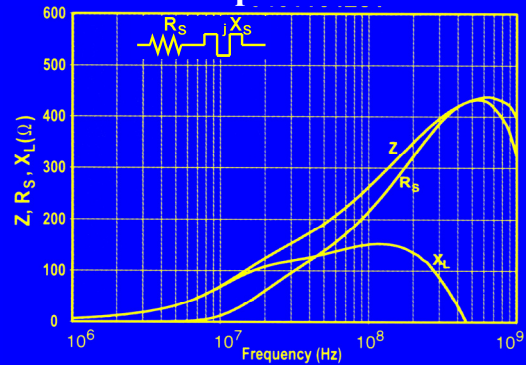

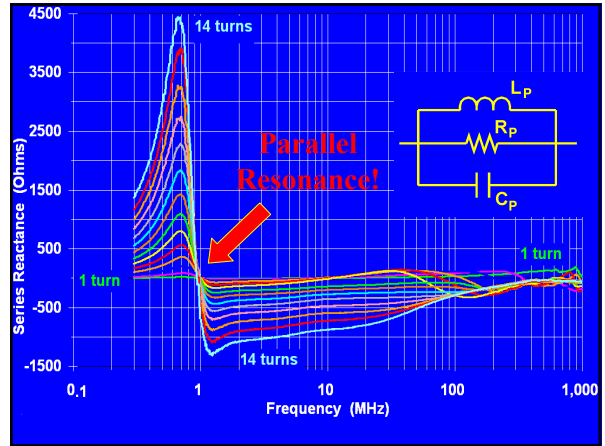
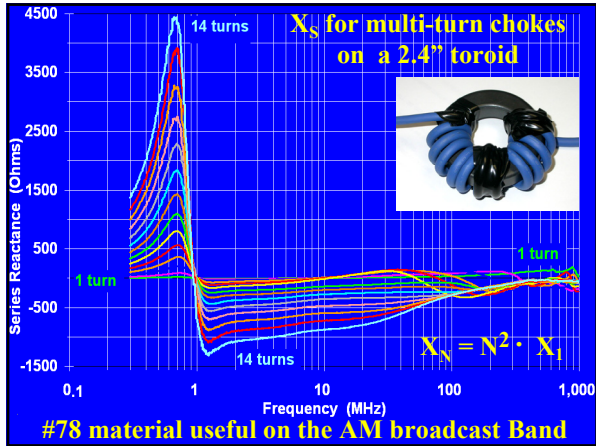

**What Causes this Resonance?**

The ferrite material (the *mix*), and  
The physical dimensions of the ferrite core.

- There is a finite velocity of propagation within the ferrite
- There are standing waves within the core when the cross-section is a half-wavelength
- Frequency of the resonance depends on:
  - Velocity of propagation (depends on the “mix”)
  - Dimensions of the cross-section of the flux path

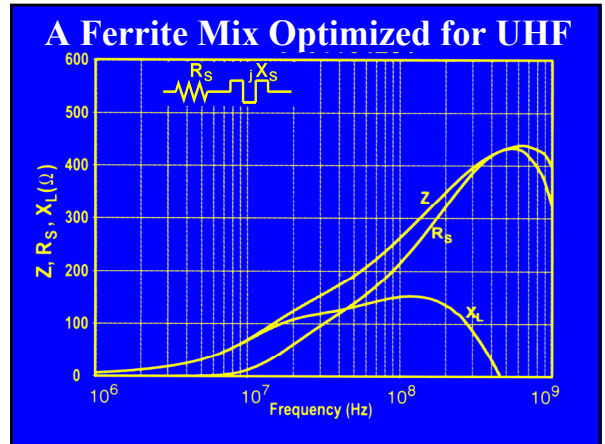
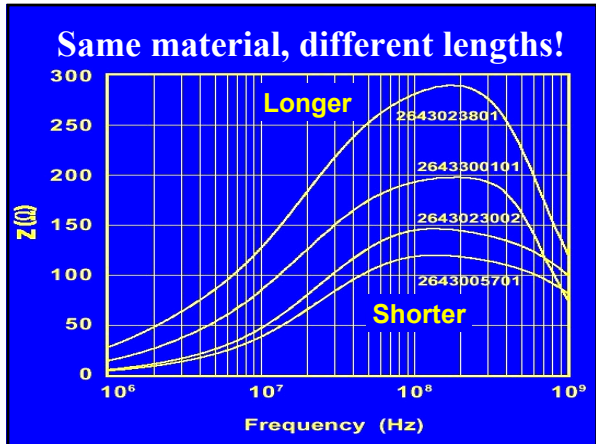
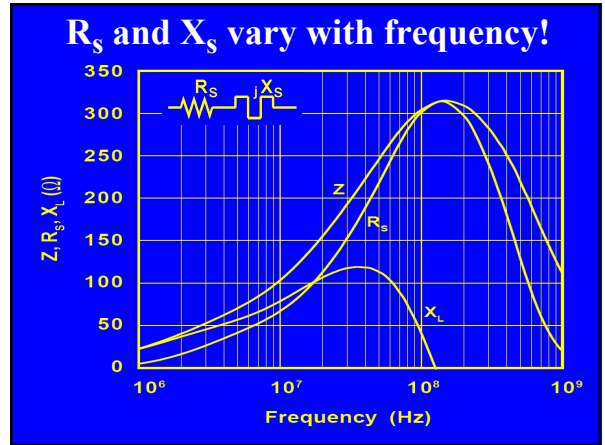



## Audio Cable is Lossy at RF

- RF is detected within equipment.
- RF that gets in at a distance will be attenuated by the cable.
- It's RF that gets onto the cable close to the equipment that matters most.
- So put the ferrite choke very close to the equipment that is detecting the RF

## Let's Test Our Equivalent Circuit

It looks OK for the #78 material at low frequencies, but look at high frequencies – there is another resonance up there!

$L_D$  and  $C_D$  describe the *dimensional resonance*.  
 $R_D$  accounts for the *losses* in the ferrite.

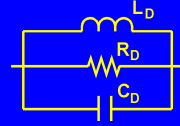

We need a more complex equivalent circuit.

## General Equivalent Circuit

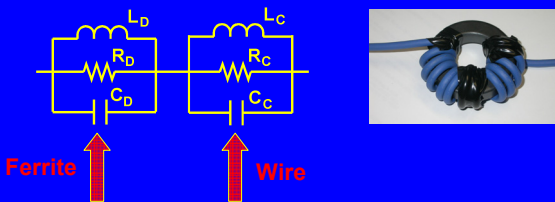

$L_C$  is the inductance of the coil  
 $C_C$  is the stray capacitance of the coil  
 $R_C$  is the resistance of the wire.  
 $L_C$  and  $C_C$  is the resonance that moves!

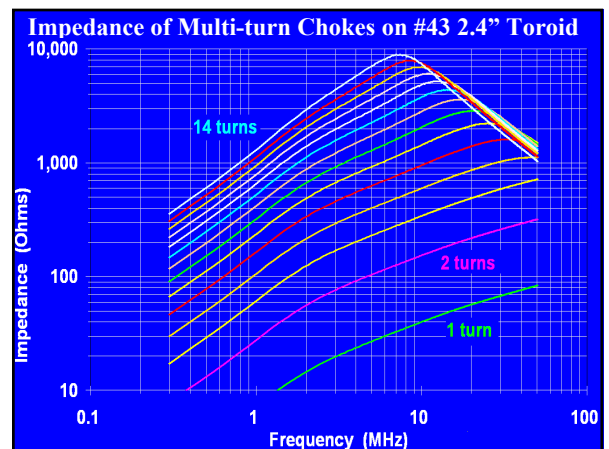
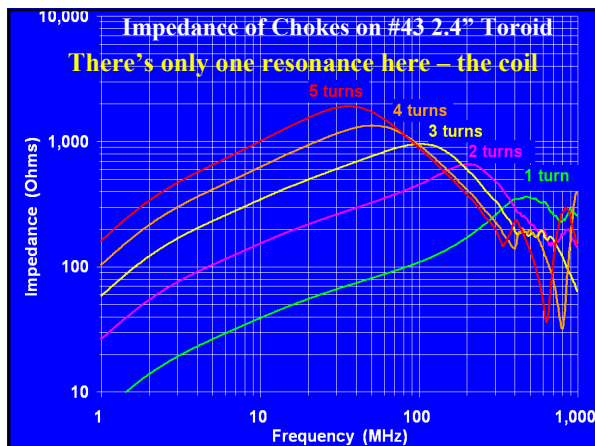
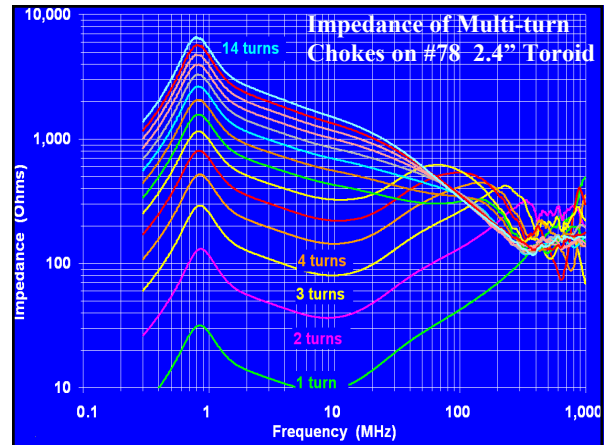

## Why no Dimensional Resonance?

The #78 is MnZn, while this one is NiZn

- $V_p$  in #43 is much higher, so dimensional resonance would occur at VHF rather than MF
- At VHF, there is so much loss that it damps the standing waves that would produce dimensional resonance

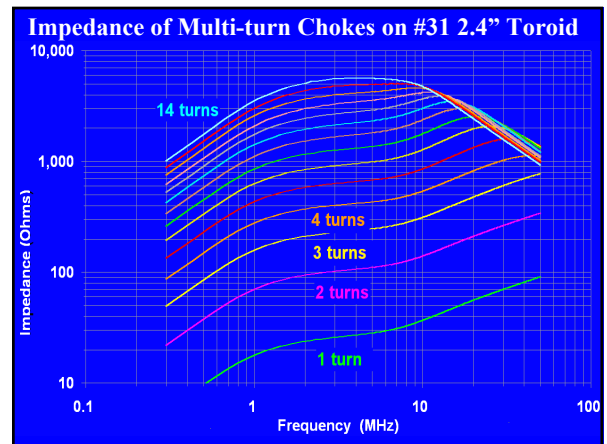
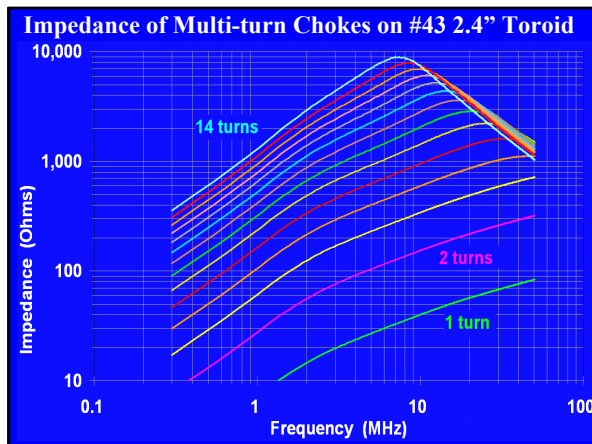
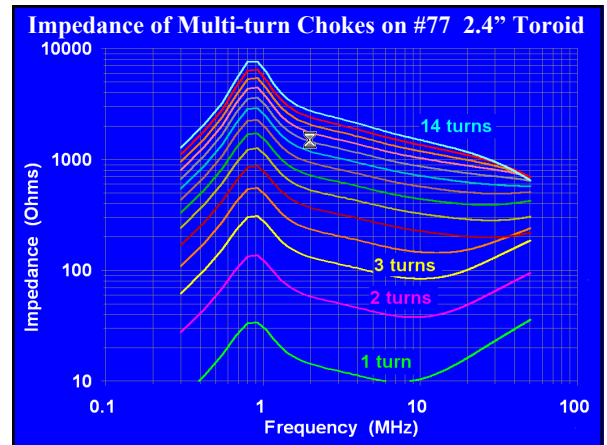
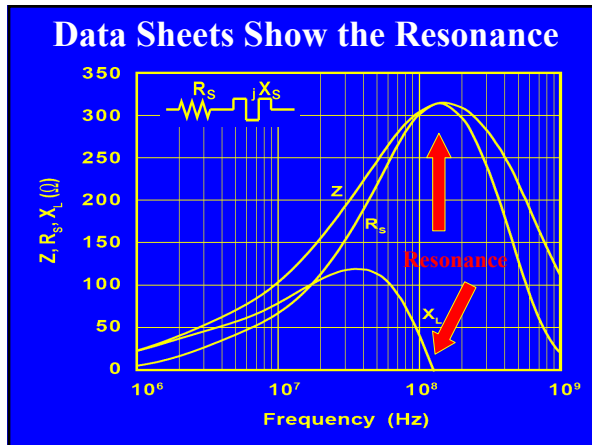
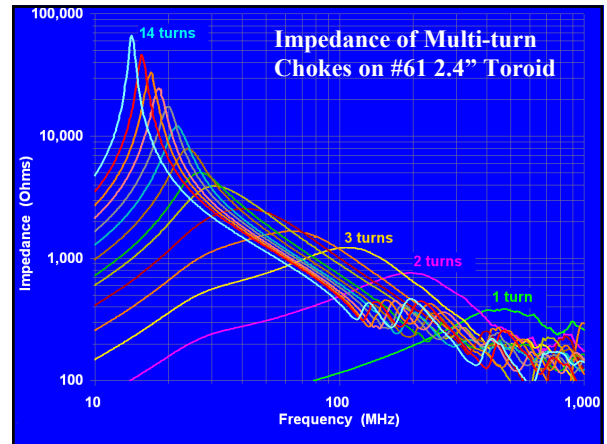

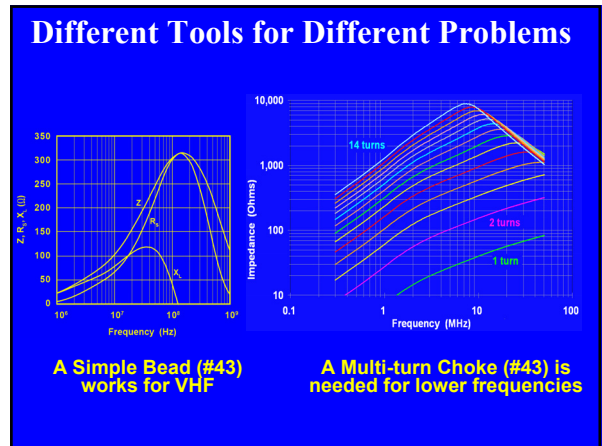
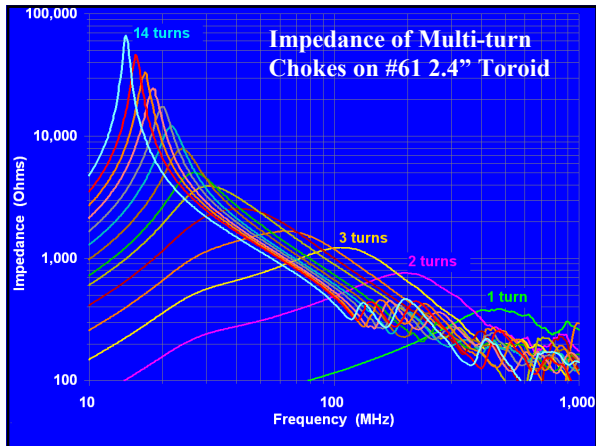

### So How do We Use These Tools?

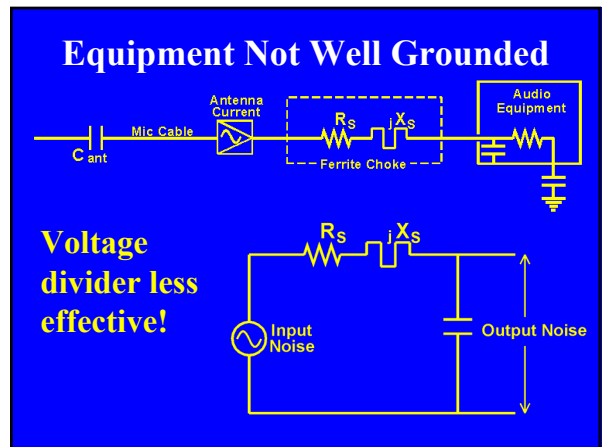
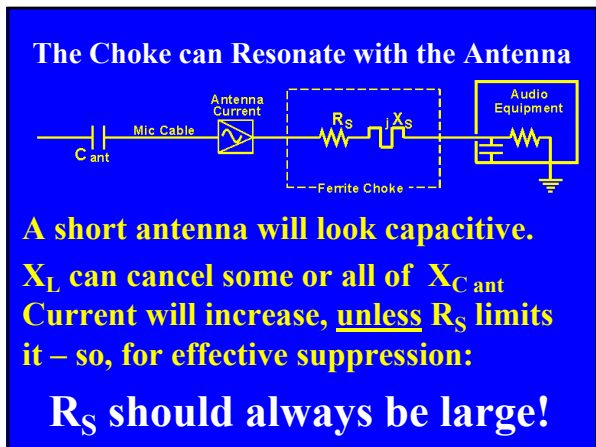
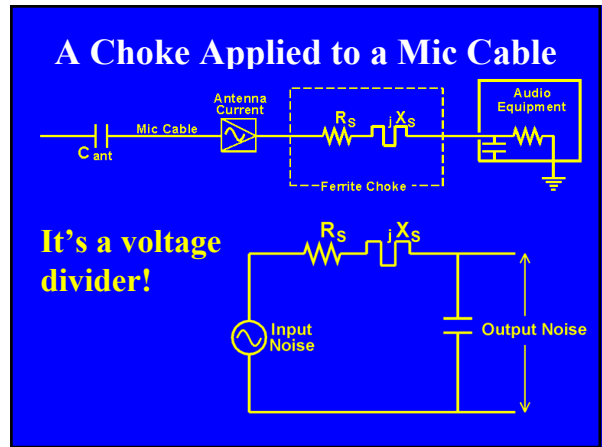

## Criteria for Good Suppression

- Choke should be predominantly resistive
- With voltage divider (capacitor across input)
  - A few hundred ohms can be very effective
- No voltage divider (brute force)
  - At least 700 ohms needed, more is better
- 700 – 1,000 ohms  $R_S$  should be a “minimum” design goal

## Capacitance Can Help a Lot

- Outside the box, we’re stuck with what the designer provided, so a big ferrite is needed
- Inside the box, we can use a smaller ferrite part if we provide the capacitor

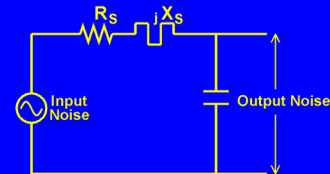

## You May Not Need an Elephant Gun

- Most detection is square law, so:
  - A 10 dB reduction in RF level reduces audible interference by 20 dB

## Threshold Effect

- For “brute force” suppression, the ferrite choke should add enough series  $R$  that the resulting  $Z$  is 2X the series  $Z$  of the “antenna” circuit without the choke. This reduces RF current by 6 dB, and detected RF by 12 dB.
- Very little suppression occurs until the added  $R$  is at least half of the starting  $Z$ .

## Threshold Effect

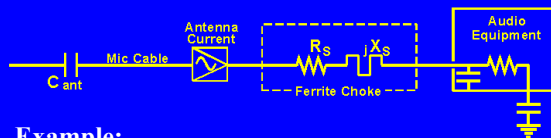

### Example:

Without the choke, the total antenna circuit is  $300 \angle -60^\circ$ , and we add a choke that is  $300 \angle 60^\circ$ , bringing the series  $Z$  to  $300 \angle 0^\circ$ . The current doesn't change. Additional  $R_S$  will begin to reduce the current, but  $R_S$  must increase to  $600 \Omega$  to reduce detected RF by 12 dB (assuming no change in  $X_S$ ).

## How About Ham Radio?

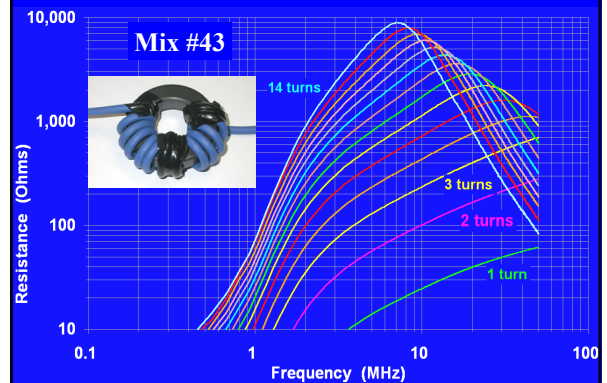

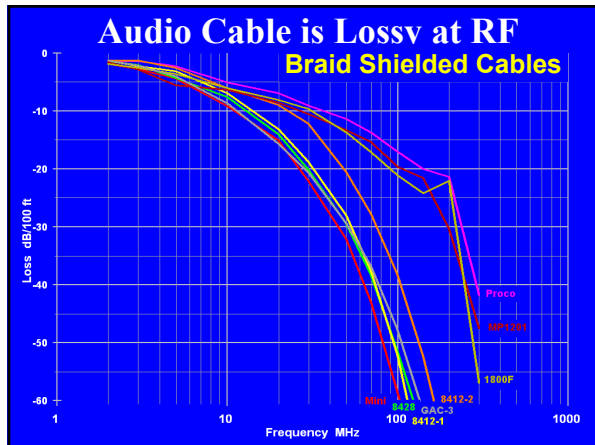
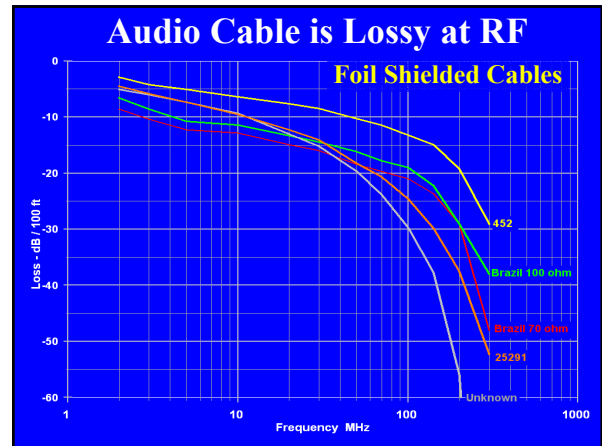
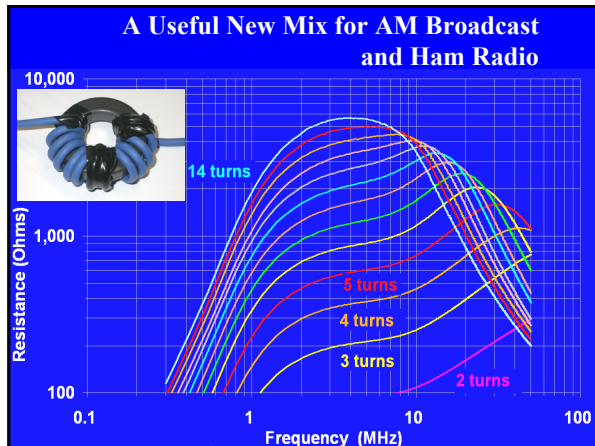

- ### Audio Cable is Lossy at RF
- RF is detected within equipment
  - RF that gets in at a distance will be attenuated by the cable
  - It's RF that gets onto the cable close to the equipment that matters most
  - So put the ferrite choke very close to the equipment that is detecting the RF

- ### Cell Phones
- Use several #61 beads
    - Select for  $>350 \Omega$  at 800 MHz
    - Use at least three beads
    - Put beads very close to equipment receiving interference

- ### Guidelines for Suppression
- Put choke within  $\lambda/20$  of equipment
    - Cable between choke and equipment will act as antenna
  - If interconnect wiring  $> \lambda/10$ , suppression may be needed at both ends
  - When chokes in series to cover multiple frequency ranges, highest frequency choke should be nearest to equipment

### Choosing a Ferrite Part

- Below resonance,  $Z$  will be approximately proportional to:
  - Length of part that surrounds the wire
  - $\ln(D/d)$  where  $D$  is the outer diameter and  $d$  is the inner diameter
  - $N^2$
  - $\mu$  (varies with frequency)

### Choosing a Ferrite Part

- Thus, to maximize suppression use a part that:
  - is longer
  - fits the wire most snugly
  - is thicker
  - is of a material has greater series R

### Resonance and Suppression

- Ferrite chokes for suppression generally:
  - provide the greatest suppression at resonance
  - are effective for <1 octave above resonance
  - are effective for 1-3 octaves below resonance

### Ferrites and Loss

- Ferrites for suppression should be very “lossy” within the spectrum they need to suppress
- Ferrites for transformers and inductors should have as little loss as possible within the spectrum where they are operating

### Other Ferrite Characteristics

- The resistivity varies over 5 orders of magnitude from one mix to another
  - Some are good insulators
  - Some are rather conductive
- Ferrites saturate at high signal levels, reducing  $\mu$
- $\mu$  decreases with increasing temperature

### Measuring Ferrite Chokes

- Antenna Analyzer (\$500 - \$2,000)
  - AEA CIA-series
- Lab Test Equipment (\$10K - \$30K)
  - Network Analyzer
  - Impedance Bridge or Analyzer
- RF generator, series resistor, and voltmeter (or scope, or spectrum analyzer)

HP8753C w/HP85046A S-parameter Test Set

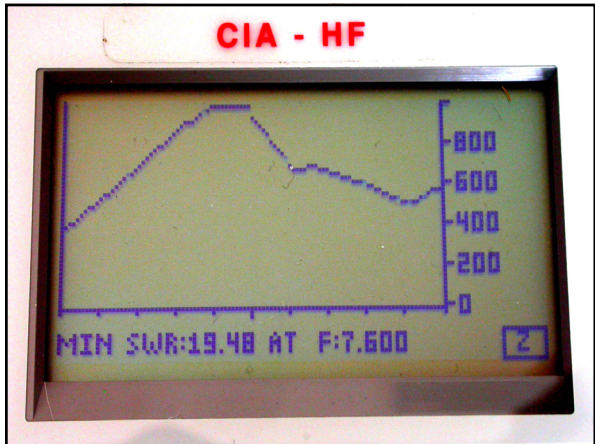
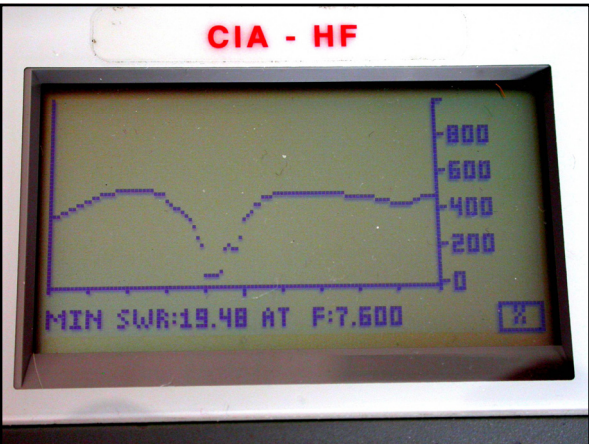
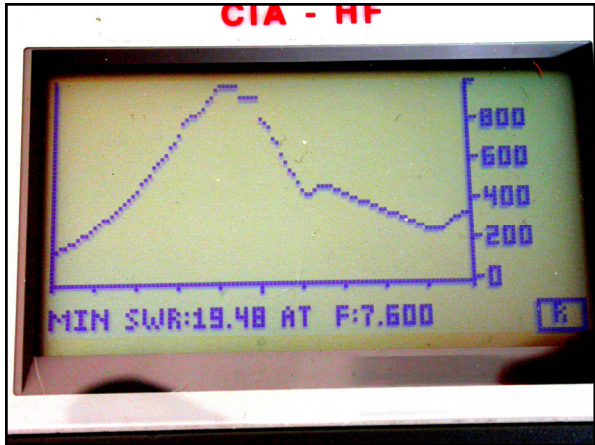
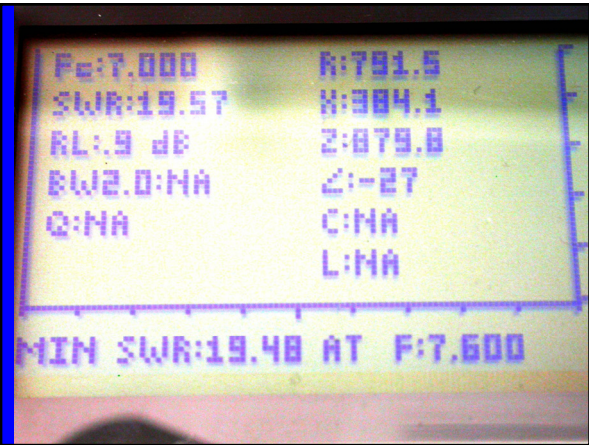

### Limitations of CIA and MFJ

- **Input capacitance 15 pF detunes the choke**
  - Moves resonance down (sometimes a lot!)
- **Input resistance of 1.5K ohms limits accuracy at high impedance**
- **Accuracy degrades for  $Z_X \gg 50$  ohms**
- **Don't trust Z at frequencies > 10 MHz**

### Measured With Lab-Quality Gear

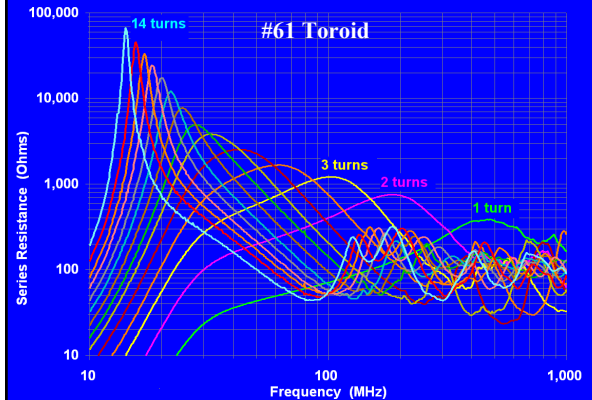

### Measured With AEA CIA-HF

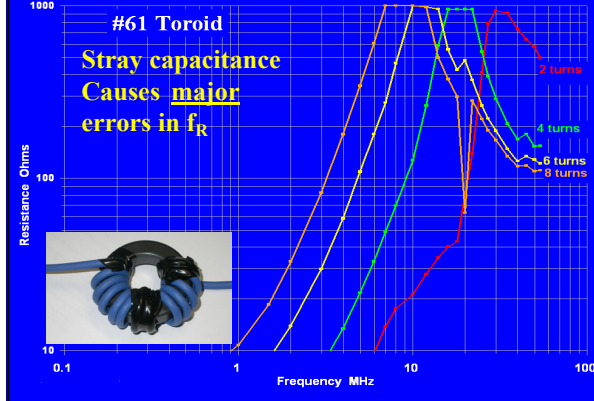

### Three Kinds of Ham RFI

- **Interference from ham radio to other gear**
- **Interference to ham radio**
- **RF in the shack**

### Basic Interference Mechanisms

- **Pin 1 problems (both ways!)**
  - Fix them
  - Chokes can help
- **Coupled on input and output wiring**
  - Low pass filters
  - Chokes can help
- **Radiated directly to/from circuitry**
  - Shield equipment and ground the shield
  - Good interior design to minimize loops
  - Chokes cannot help

### The Principle of Reciprocity

- **If the mechanism is passive, what helps minimize received interference will generally also help reduce transmitted noise**
  - Anything Digital
  - Anything with a microprocessor
  - Anything with a clock (or oscillator)
  - Computers
  - Appliances
  - Home Entertainment
  - Power supplies



### What Needs to Be Choked for Ham RFI to Home Entertainment Systems?

- **Anything that can act as an antenna!**
  - RF coax lead-ins
  - Video cables
  - Audio cables
  - Power cables

### RFI to Telephones

- **Try ferrite chokes first**
  - Telephone wiring
  - Power supply
- **Common mode chokes**
  - K-Com bifilar-wound choke, about 15 mH
  - A lot more choke than you can easily do yourself
  - <http://www.k-comfilters.com>

### RFI to Doorbells, DC Alarm Circuits

- **Simple low-pass filters**
  - Series choke, parallel capacitor
  - Series resistor, parallel capacitor
  - K-com filters

### RFI to Ground Fault Interrupters (GFCI)

- **Detects imbalance between hot (phase) and neutral, interrupts if > 5 mA**
- **There's active electronics inside**
  - Can false trigger on RF (mostly HF)
  - Add 0.1  $\mu$ F 1 kV capacitor between phase and conduit

### Identifying RFI to the Ham Bands

- **Check your own house first!**
  - Kill power to your house and listen with battery power
- **With power restored, listen with a talkie that covers HF**
- **RF noise from power lines is mostly arcing at insulators, almost never from transformers**
- **Use a directional antenna to listen at VHF, even when problem is at HF**
- **At HF, listen to the "grounding" downloads**

### Common RF Noise Sources at Home

- **Anything Digital**
- **Anything with a microprocessor**
- **Anything with a clock (or oscillator)**
- **Anything with a motor or switch**
  - Computers
  - Appliances
  - Home Entertainment
  - Power supplies
  - Radios

### Some Notorious RFI Sources

- **Electric fences**
- **Battery chargers for:**
  - Power tools (drills, etc.)
  - Golf carts
  - Lawn mowers
- **Power supplies for:**
  - Low voltage lighting
  - Computers
  - Home electronics

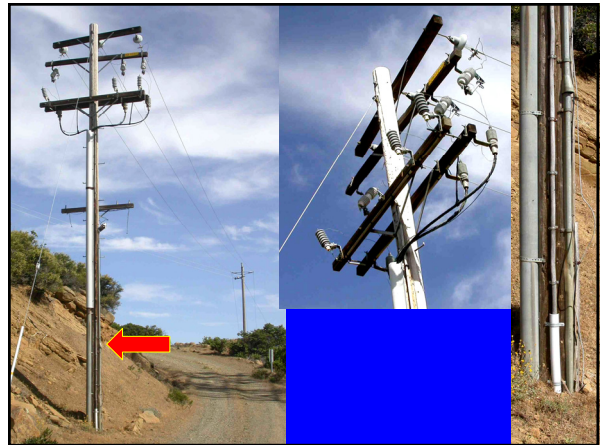

### Some Ethernet Birdies

- |              |              |
|--------------|--------------|
| • 3,511 kHz  | • 28,105 kHz |
| • 10,106 kHz | • 28,181 kHz |
| • 10,122 kHz | • 28,288 kHz |
| • 14,030 kHz | • 28,319 kHz |
| • 21,052 kHz | • 28,350 kHz |
| • 28,014 kHz | • 28,380 kHz |

All frequencies are approximate

### Ethernet Birdies

- **Identify by killing power to router or hub**
- **Even when you fix your own, you may hear your neighbors (I do)**
- **Methods of radiation**
  - The ethernet cable is a (long wire) antenna
  - Direct radiation from the switch, hub, router, computer, and their power supplies
  - Power supply cables are antennas

## Ethernet Birdies

- Chokes will kill the common mode radiation (long wire) from the cable
- Use choke(s) on each cable (and each end of long cables) (Each end talks)
- Use multiple chokes if needed for wide frequency ranges, putting highest frequency choke nearest to noise source
- Choke the power supply too!

## A Look at Baluns

- A W2DU balun (called a “current” or “choke” balun) is simply a lot of beads strung onto the end of the coax
- All baluns are not created equal!
- It is possible to overheat and short out a W2DU balun with too much current
  - That resistance is real, and the power it dissipates can “cook” the coax!
  - I’ve done it with 100 watts!

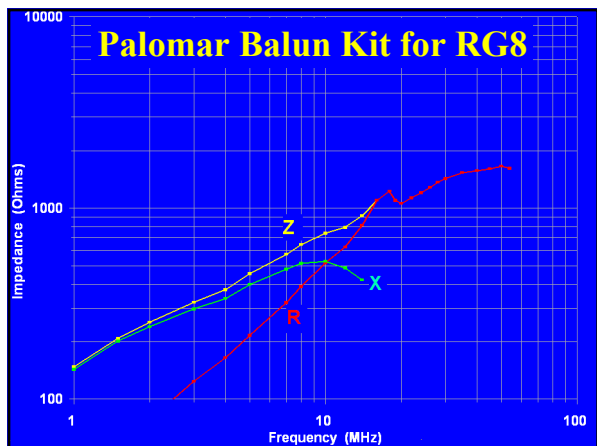
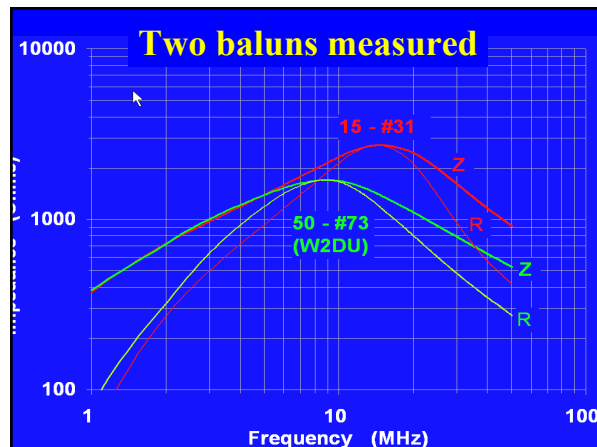
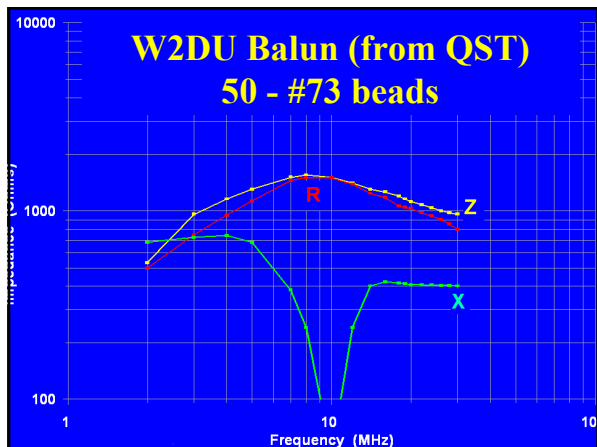

## Acknowledgements

- Bill Whitlock
- Ron Steinberg (K9IKZ)
- Leo Irakliotis (KC9GLI)
- Neil Muncy (ex-W3WJE)
- Steve Kusiceil
- Fair-Rite Products

## References

- ***Fair-Rite Products Catalog*** This 200-page catalog is a wealth of product data and applications guidance on practical ferrites. This company is a class act. <http://www.fair-rite.com> The vast majority of ferrite parts available at retail in the US are made by Fair-Rite.
- ***Ferroxcube Catalog and Applications Notes*** More online from another great manufacturer of ferrites. <http://www.ferroxcube.com>
- E. C. Snelling, ***Soft Ferrites, Properties and Applications***, CRC Press, 1969 The bible on ferrites, but heavy math and physics.
- Henry Ott, ***Noise Reduction Techniques in Electronic Systems***, Wiley Interscience, 1988 ***The best book there is on EMC.***
- ***ARRL RFI Book***
- Marv Loftness, ***AC Power Interference Handbook (ARRL)***
- Applications notes on my website – <http://audiosystemsgroup.com>

## Understanding and Eliminating RF Interference

**Jim Brown (K9YC)**

**Audio Systems Group, Inc.**

<http://audiosystemsgroup.com>